

RoHS
Compliant

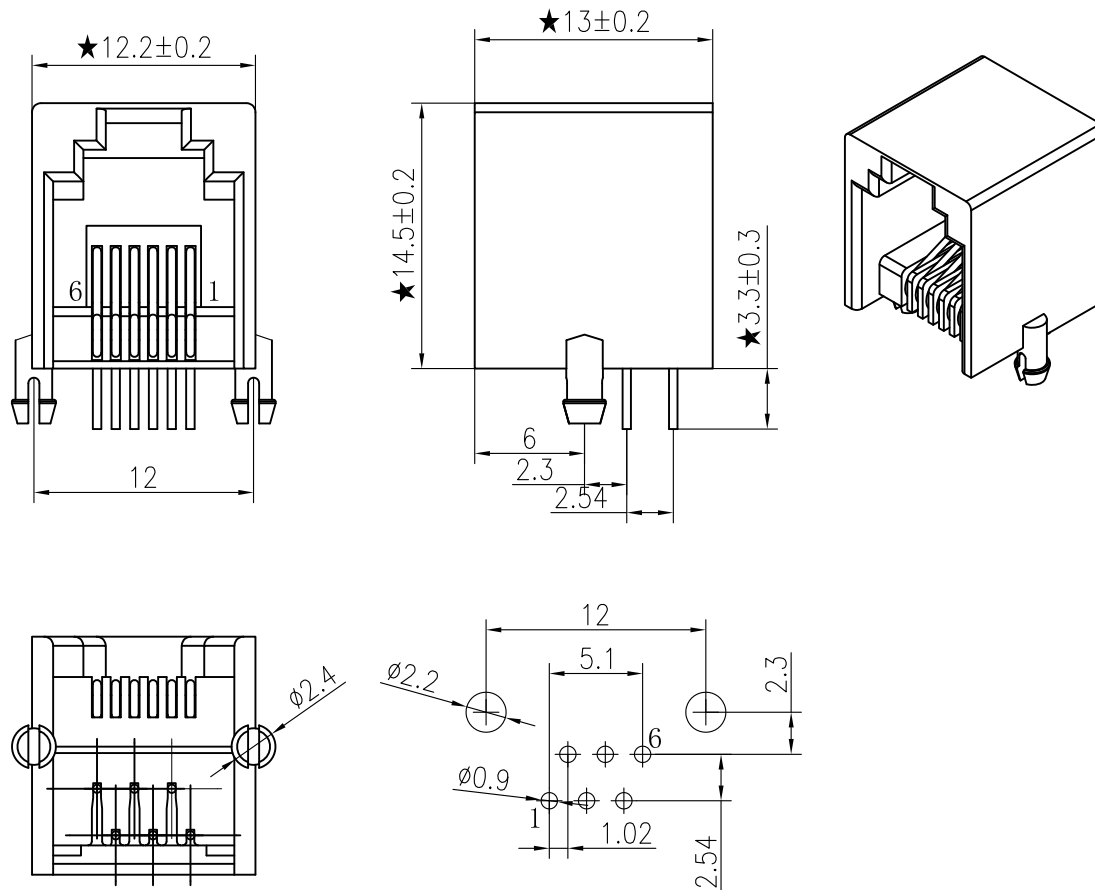

NOTES

MECHANICAL:

1. HOUSING MATERIAL: PBT BLACK UL94V-0
2. CONTACT MATERIAL: PHOSPHOR BRONZE $\phi 0.46\text{mm}$.
3. PLATING: GOLD PLATING AT CONTACT AREA, NICKEL 30u" MIN. OVER ALL
4. OPERATING LIFE: 750 CYCLES MIN.
5. MATING/UNMATING FORCE: 30N/3.06KGf MAX
6. RETENTION STRENGTH: 50N MIN. FOR 60S±5S

ELECTRICAL:

1. VOLTAGE RATING: 125 VAC RMS.
2. CURRENT RATING: 1.5 AMP.
3. CONTACT RESISTANCE : 30m Ω MAX.
4. INSULATION RESISTANCE: 1000M Ω MIN. AT 500V DC.
5. DIELECTRIC STRENGTH: 1000V AC OR 1500V DC RMS AT 0.5mA 50Hz/60Hz FOR 1MINUTE.

ENVIRONMENTAL:

1. STORAGE: -40°C TO +85°C RELATIVE HUMIDITY<80%.
2. GUARANTEE PERIOD: 12 MONTHS
3. OPERATION: -40°C TO +85°C.
4. The mark with ★ is the key inspection dimension for QC

PC BOARD LAYOUT

NO.	PACKING	PART NO.	Gold Plating
1	TRAY	WFD55A511SX0011D1111000	Fu"
2		WFD55A511SX0021D1111000	1u"
3		WFD55A511SX0031D1111000	3u"
4		WFD55A511SX0041D1111000	6u"
5		WFD55A511SX0051D1111000	15u"
6		WFD55A511SX0061D1111000	30u"
7		WFD55A511SX0071D1111000	50u"

					TOLERANCES				TITLE							
					.X	±0.30				WFDCONN 深圳市旺富达电子有限公司 SHEN ZHEN WFD ELECTRONICS CO., LTD						
					.XX	±0.25				RJ11 JACK 1X1 6P6C W/O SHIELD						
					.XXX	±0.10				PART NO. SEE TABLE						
					PROJECT				APPROVAL	CHECK	DRAWN	DATA	UNIT	SCALE	CHECKED	REV
DATE	REV	DESCRIPTION	CHECK	APPROVAL					DAVID	SIMON	LIU MIAO	2021/10/06	MM	1:1		A4