

REV	DESCRIPTION	APPR	CHECK	DRAW	DATE
△	原始图档		SIMON	Liu Miao	120620

RoHS
Compliant

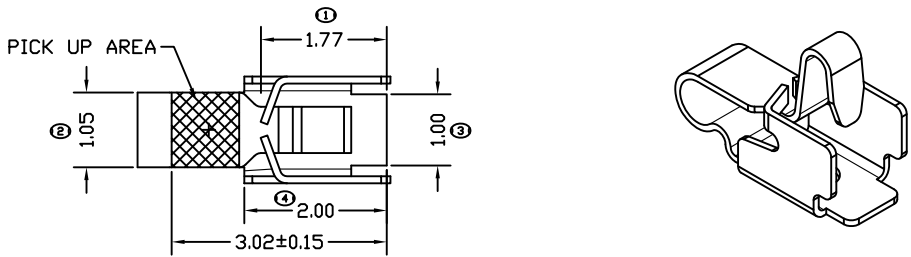

- PRODUCT NO.
1. SPECIFICATIONS:
- 1.1. CONTACT RESISTANCE:80MΩ MAX
 - 1.2. VOLTAGE RATING:1.5V/AC/DC/MAX
 - 1.3. CURRENT RATING:1.0A/MAX
 - 1.4. PRE-LOAD FORCE:0.5±0.1N ON CONTACT POINT
 - 1.5. MAX.BEAM DEFLECTION:0.7±0.1N ON CONTACT POINT
 - 1.6. DURABILITY:200 CYCLES
 - 1.7. DPERATING TEMPERATURE:-20°C~80°C
2. MATERIAL:
- 2.1. STAINLESS STEEL SUS301 T=0.10MM
3. FINISH:
- 3.1. 1u"AU ON CONTACT AREA
 - 3.2. GOLD FLASH PLATING ON SOLDER AREA
 - 3.3. 80u" MIN. NICKEL UNDERPLATING OVERALL

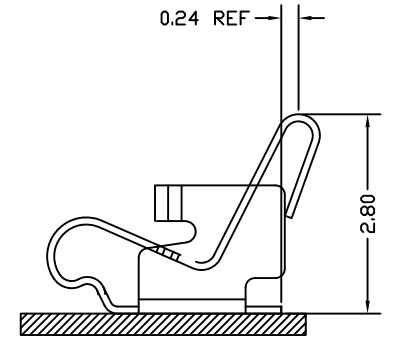
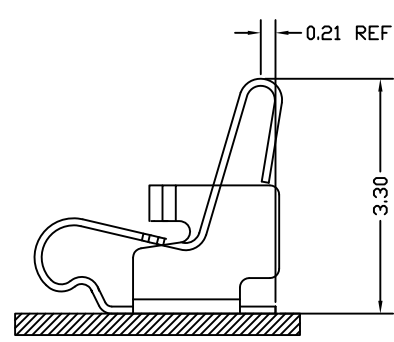
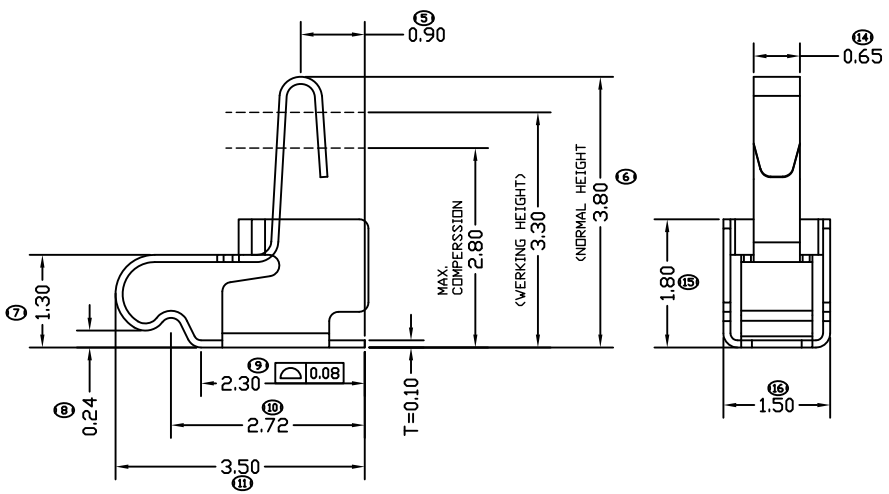

STATE AT WORKING HEIGHT(H=3.30)

STATE AT WORKING HEIGHT(H=2.80)

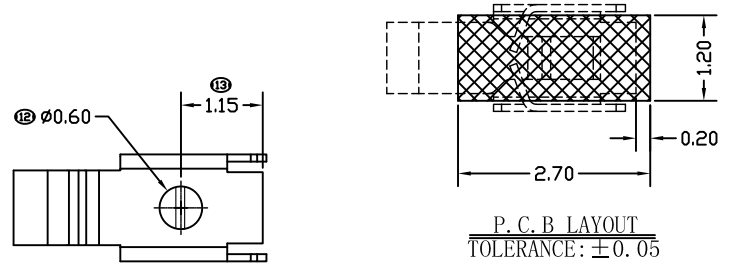

QUALITY SYMBOLS	GENERAL TOLERANCES (UNLESS SPECIFIED)		SCALE: 1:1	NUMBER:	WFDconn 深圳市旺富达电子有限公司 Shenzhen WFD Electronics Co.Ltd..
		MM	INCH	MATERIAL: HRC:	
▽0	.X	±0.25	.X	④----	TITLE: 3.8H 带扣弹片
	.XX	±0.20	.XX	⑤----	
	.XXX	±0.15	.XXX	⑥----	THIRD ANGLE PROJECTION REVISE ON CAD ONLY
▽C0	ANGULAR ±1°				
DRAFT WHERE APPLICABLE MUST REMAIN WITHIN DIMENSIONS					PART NO. WFD-3001M2160022-6
DRAWN BY: Liu Miao			DATE: 120620		DWG NO.
CHECKED BY:			DATE:		SHEET NO. 1/1
APPROVED BY:			DATE:		A4