

REV.	ECN NO	LOCATIONS	DESCRIPTION	DATE

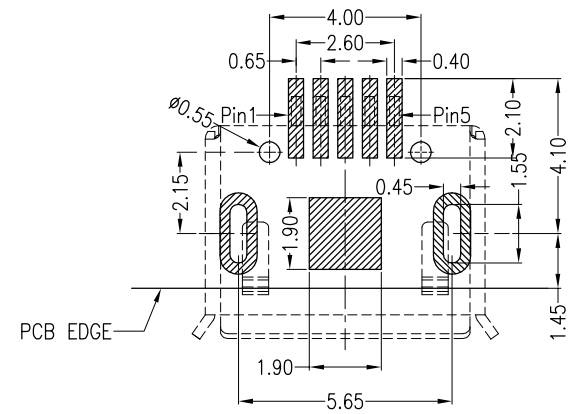
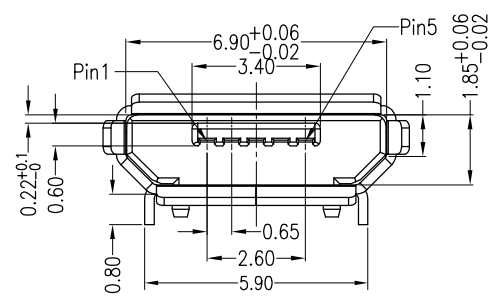
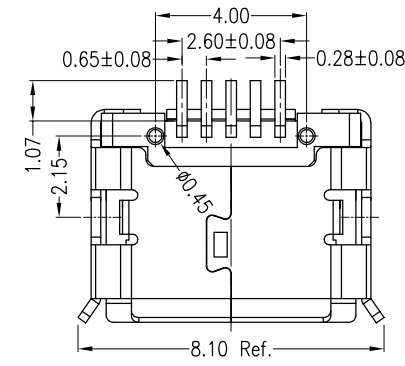
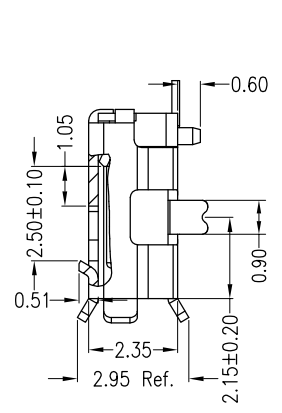
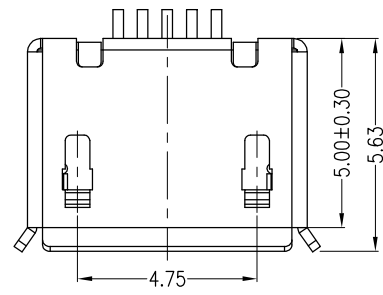
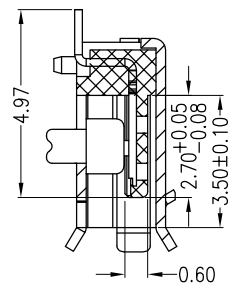
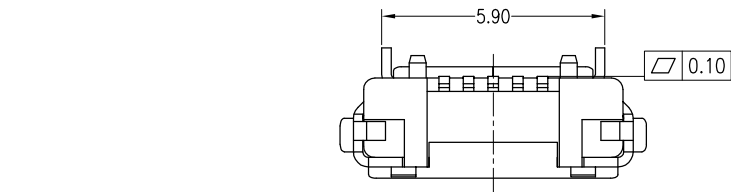

RECOMMENDED PCB LAYOUT
PCB图仅供参考

- Note:
- Material:
 - Housing: High temperature thermoplastic with g.f,UL94v-0
 - Contact: copper alloy,t=0.20mm
 - Shell: copper alloy,t=0.25mm
 - Specification:
 - Current rating:1,5PIN 1.8A Max/2,3,4PIN 1A Max.
 - Dielectric withstanding voltage: 100 V(ac) for 1 min.
 - Contact resistance: 30 mΩ Max.
 - Insulation resistance: 100 MΩ Min.
 - Total mating force: 3.57 Kgf Max.
 - Total unmating force: 1.0 Kgf Min.
 - Temperature range: -30°C~80°C

外壳材质
1:C288R-H

外壳电镀
1:NEUJ'
2:雾150J'
3:N+Au1u' (脚)
4:Au1u'

端子电镀 01:Au1u' ;02:Au1.5u' ;03:Au1'
05:Au5u' ;10:Au10u' ;15:Au15u' ;30:Au30u'

主体颜色 B:黑色

主体材质 1:LOP

端子材质 4:CS191R-BH

PART NO: USB-F06505-SC083		MATERIAL: SEE NOTE		WFDconn 深圳市旺富达电子有限公司 SHEN ZHEN WFD ELECTRONICS CO., LTD	
MODEL NO: XX		FINISH: SEE NOTE			
UNIT: MM	SIZE: A4	COLOR: SEE NOTE		TITLE: Micro usb 5s B Type 有脚柱(插板5.9)加长0.75	
TOLERANCE UNSPECIFIED		DR: LIU MIAO		DWG NO: A135	
.x 0.15		CHK: SIMON		REV: A	
.xx 0.10		APP: DAVID		SCALE: 5:1	
.xxx 0.05				DATE: 2012.06.04	
Ang. 1°					