

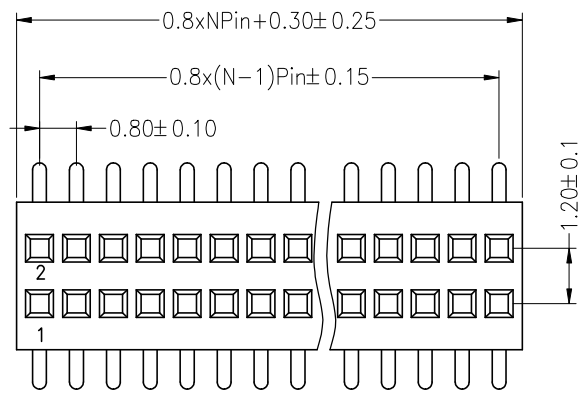

SPECIFICATIONS
 Rated Current: 0.75AMP
 Contact Resistance: 30mΩ Max
 Withstand Voltage: 500V AC/DC
 Insulation Resistance: 1000MΩ Min
 Operation Temperature: -40°C to +105°C

Contact Material: Phosphor Bronze
 Contact Plating: Au or Sn Over Ni
 Insulator Material: Polyester (UL94V-0)
 Standard: LCP
 Soldering temperature: 260°C ± 5° 5S



Recommended P.C.B Layout (Top Side)
 (PCB BOARD TOLERANCE ± 0.05)

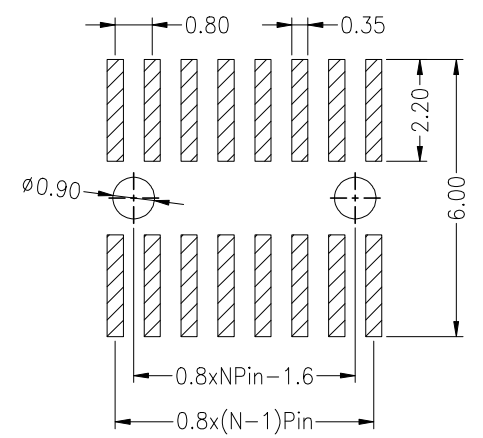

Ordering Information

2731 02 XX X X XX M U X 0X

- No. of Pins Per Row: 2-50
- Insulator Material Option: C=BK-PA6T, E=BK-PA9T, F=BK-LCP
- Post: W=With Post, N=W/O Post
- Contact Plating: G1:Gold Flash, G3:2U" Gold, G4:3U" Gold, G5:5U" Gold, G6:10U" Gold, G7:15U" Gold, S0:Gold Flash/Tin
- Packing: A=Tray, T=Tube, P=Tube+Cap, R=Reel+Cap, M=Reel+Mylar

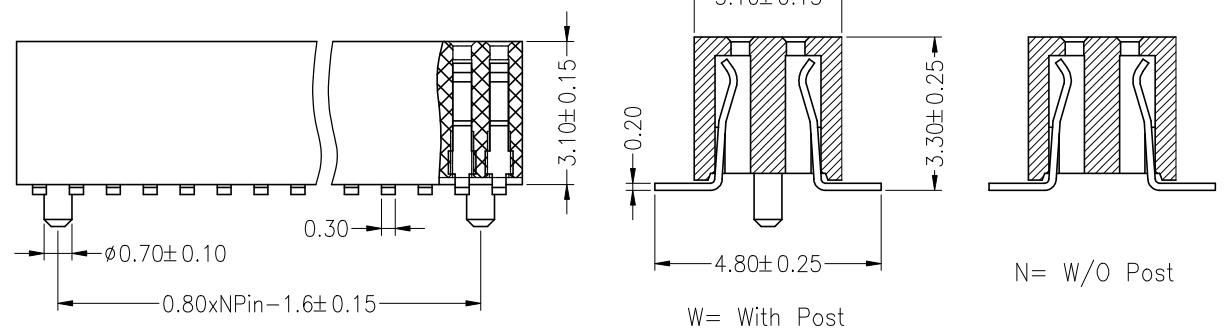

OPERATION		DRAW	Liu Miao	12.03.28
X.X	± 0.30			
X.XX	± 0.20	CHECK		
X.XXX	± 0.10			
Angle	± 3°	APPROVE		
DIM	TOL			

SCALE	FIT	WFD 深圳市旺富达电子有限公司 SHEN ZHEN WFD ELECTRONICS CO., LTD	
UNIT	mm		
SIZE	A4	PART NO.	273102XXXXXXMU0X
SHEET	1/1	TITLE:	0.8PF 2xNPin H3.10 SMT
PROJ.			

REV	DATE	MODIFICATION DESCRIPTION	CHANGE
A0	2012.03.28	NEW DRAWING	