

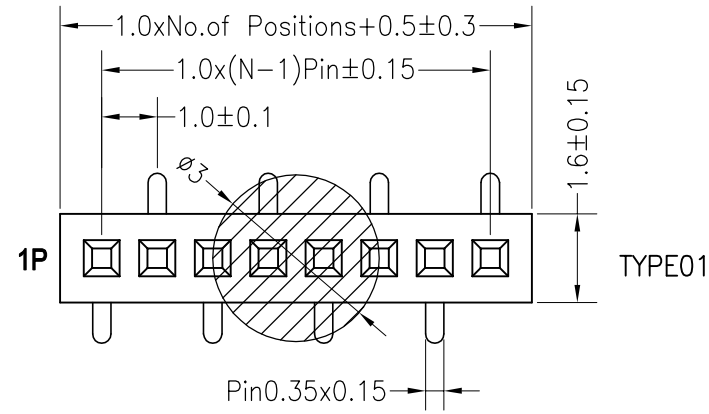

SPECIFICATIONS

Rated Current:0.75AMP
 Contact Resistance:30mΩ Max
 Withstand Voltage:500V AC/DC
 Insulation Resistance:1000MΩ Min
 Operation Temperature:-40°C to +105°C

Contact Material:Phosphor Bronze
 Contact Plating:Au or Sn Over Ni
 Insulator Material:Polyester(UL94V-0)
 Standard: PA6T
 Max.Processing Temp: 230°C for 30-60 seconds
 (260°C for 10 seconds)

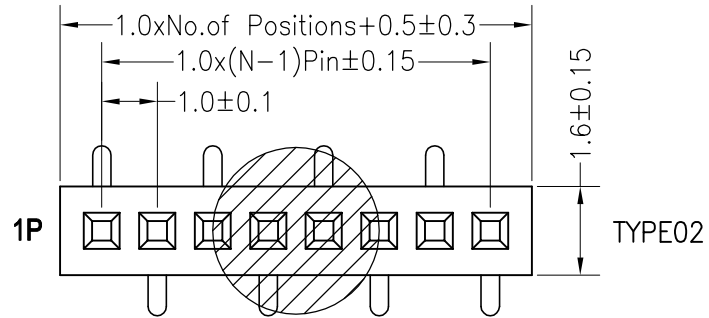

Recommended P.C.B Layout(Top Side)
 (PCB BOARD TOLERANCE±0.05)

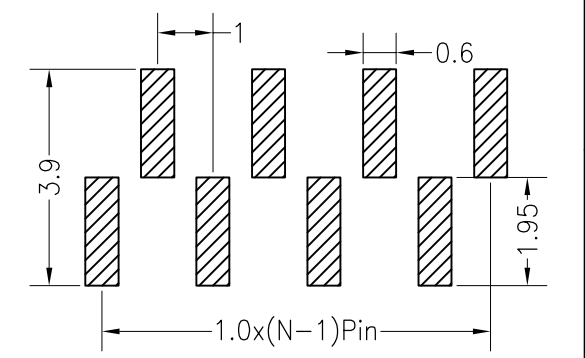
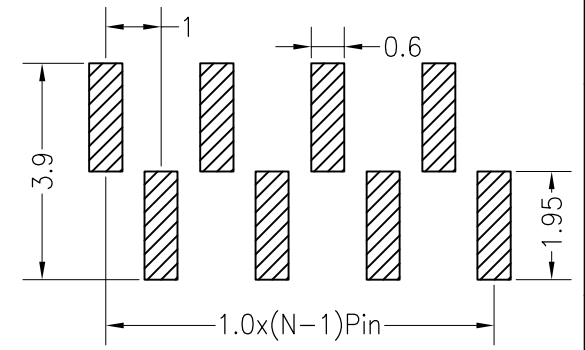

Ordering Information

2620 01 XX X N XX M U M 01 (2)

No.of Pins Per Row 1*1~1*50

Insulator Material Option
 A=BK-PBT
 B=BK-PA66
 C=BK-PA6T
 D=BK-PA46
 E=BK-PA9T
 F=BK-LCP

Contact Plating
 G0:Gold Flash
 G1:3U" Gold
 G2:5U" Gold
 G3:10U" Gold
 G4:15U" Gold
 G5:30U" Gold
 S0:Gold Flash/Tin
 SN:Tin

Packing
 O=PE Bag
 A=Tray
 T=Tube
 P=Tube+Cap
 R=Reel+Cap
 M=Reel+Mylar

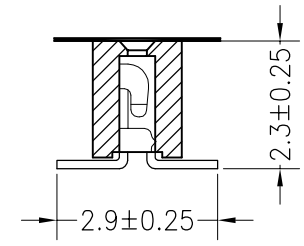
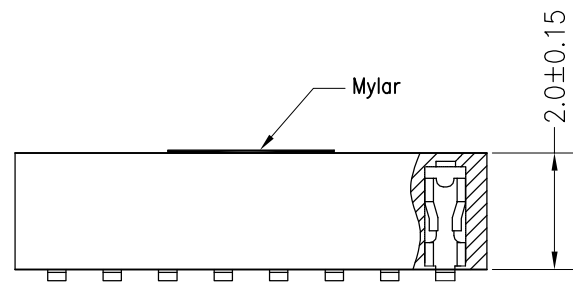

OPERATION		DRAW	Liu Miao	15.01.21	SCALE	FIT
X.X	±0.30					
X.XX	±0.20	CHECK			UNIT	mm
X.XXX	±0.10					
Angle	±3°	APPROVE			SIZE	A4
DIM	TOL					
					SHEET	1/1
					PROJ.	

WFD CONN 深圳市旺富达电子有限公司
 SHEN ZHEN WFD ELECTRONICS CO., LTD

PART NO. 262001XXXNXXMUM01(2)
 TITLE: 1.00PF H2.00mm 1XNP SMT

A0	2015.01.21	NEW DRAWING	
REV	DATE	MODIFICATION DESCRIPTION	CHANGE